

ENER-COMM™ Multi-Meter Panel

Installation & Operation Guide

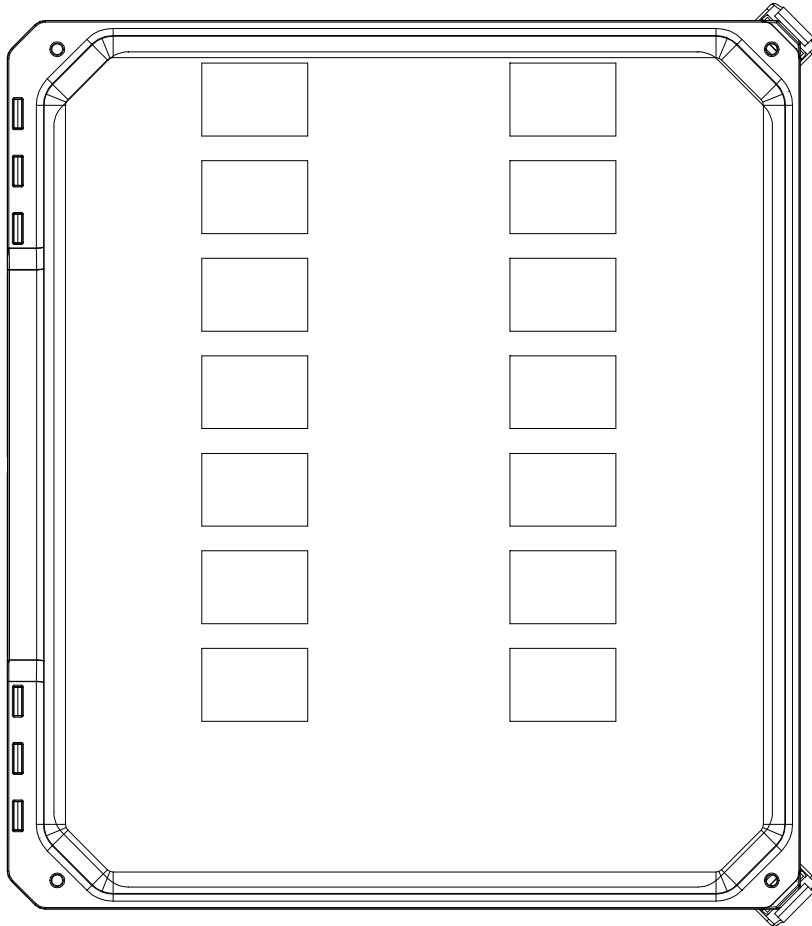

MMP 14 or MMP 6



WARNING

To reduce the risk of electric shock, always disconnect the appropriate circuit from the power distribution system before servicing or installing any VT metering product.

Global Power Products

225 Arnold Road

Lawrenceville, Georgia 30044

Phone: (770)736-8232 FAX: (770) 736-8231

www.globalpowerproducts.com

ENER-COMM Multi-Meter Panel

Installation and Operation Instructions

INTRODUCTION

Use these instructions to assemble the ENER-COMM™ Multi-Meter Panel (MMP). ***Read all instructions before you begin the installation.***

The ENER-COMM MMP Energy Meter is designed for a variety of metering configurations. It can be used as a stand-alone meter, part of an automated dial-up system or a stand-alone data recording device.

All information required to install a stand-alone meter is given in these Installation Instructions and on the diagram inside the meter enclosure. If this meter is to be used with an automated system using a modem or 485 interface, additional wiring instructions will be attached.

CONTENTS

The ENER-COMM Energy Meter is shipped from the factory in a kit containing all the hardware needed to assemble the Energy Meter. Each box contains:

<u>Description</u>	<u>Quantity</u>
Energy Meter electronics installed in a Flush Mount enclosure	1
Current Transformers (quantity depends on service type)	2 (1P 3W) 2 (Network) 3 (3P 4W Wye)

Hardware Kit containing:

- Grounding screw with grounding washer
- Wire meter seal
- Plug-on terminal blocks:
 - 4-position block for voltage (CON1)
 - 6-position block for current transformer inputs (CON 2)
 - Optional 5-position block for modem or Pulse Output

INSTALLATION

This section gives instructions for assembling and installing the ENER-COMM Energy Meter as a stand-alone unit. The ENER-COMM MMP should be installed only by a qualified electrician.

These instructions are not intended to control the interface between this product and the facility wiring. Compliance with NEC and local codes in the final applications should be verified by the local inspection authorities.

NOTE: The ENER-COMM meter is equipped with one hole in the bottom of the box to accommodate 3/4" conduit. If connecting from the bottom is inconvenient, remove the electronics and drill holes only in the lower half of the box. The upper portion of the box is used to accommodate the circuit boards.

Step 1 Mounting Enclosure

Attach the Ener-Comm MMP using the appropriate mounting hardware to a flat surface as close to the load center as possible.

Figure 1, MMP Enclosure

Step 2 Connect conduit to load center (or switchgear) and to enclosure.

Refer to Figure 2 for steps 3 through 5

Step 3 Install Current Transformers. Current Transformers can be used on the incoming lines or on individual breakers. The dot on the Current Transformer always faces the line or supply side of the service.

Typical connections for a Network or 1P 3 Wire load center →

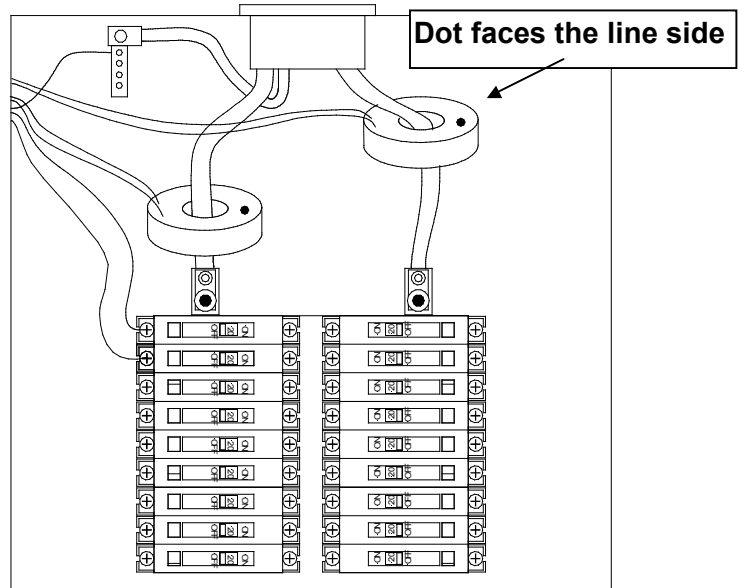

Figure 2

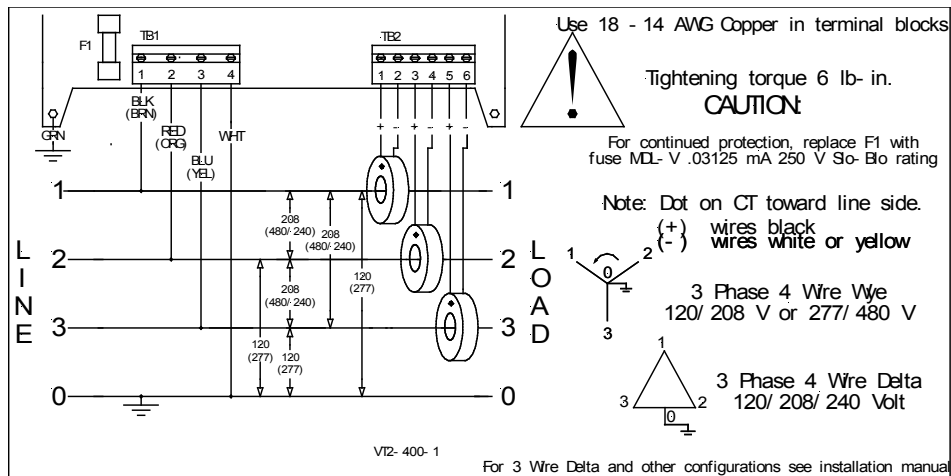

Figure 3 The MMP Voltage Connections will be similar to the TB1 Connector in the above drawing.

NOTE: It is necessary to connect all three phases of a 3 Phase 4 Wire Wye for Single Phase and Network applications to work properly.

Step 4 Make Voltage, neutral, and grounding taps.

- a) Make sure service is disconnected before make any connections.
- b) Using in-line fuses, if required by applicable electrical codes, tap each of the phase.
- c) Secure one end of a grounding lead to earth ground in the breaker panel or meter board.
- d) Attach a lead to the neutral terminal in the breaker panel or meter panel.
- e) Run voltage taps along with a secured neutral and ground tap through the conduit to the meter.

Step 5 Referring to the wiring diagram on the inside of the meter cover, terminate CT, voltage, ground, and neutral leads. See [Figure 3](#) for a 3 Phase 4 Wire Wye or 4 Wire Delta service and [Figure 4](#) for a 3 Phase 3 Wire Service.

- a) Attach ground lead to the lower left grounding point on the circuit board using the enclosed grounding washer and screw.
- b) Now you are ready to install the terminal blocks. The terminal blocks (TB1 and TB2) found in the hardware kit should be installed on the lower section of the of the board. The four terminal voltage connection block (TB1) goes on the lower left side of the board. The six-terminal current transformer connection block (TB2) goes on the lower right side of the board.
- c) Using the wiring diagram found on the inside of the meter cover, make the appropriate voltage and current lead connections. Refer to Figure 3 for a wiring diagram for a 3-Phase 4-Wire Wye or Delta service and Figure 4 for a 3-Phase 3-Wire Delta service.
- d) Align each terminal block with the pins and header on the circuit board and gently push the terminal block into place.

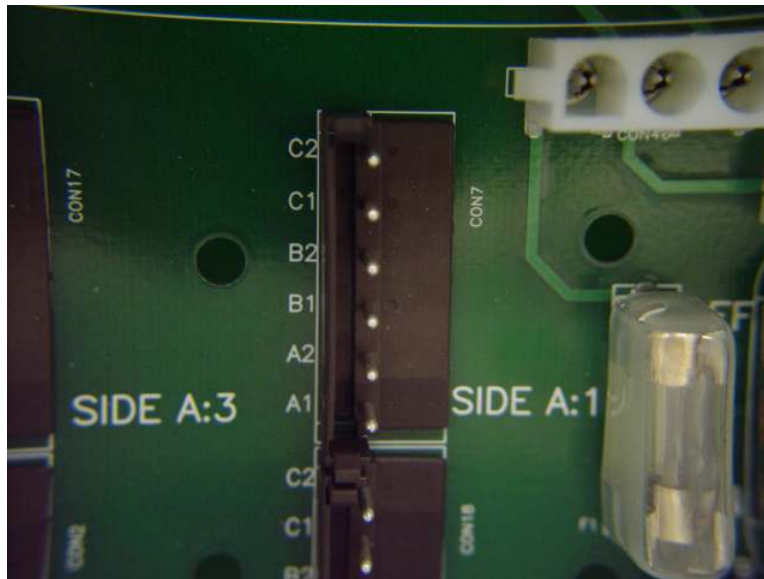

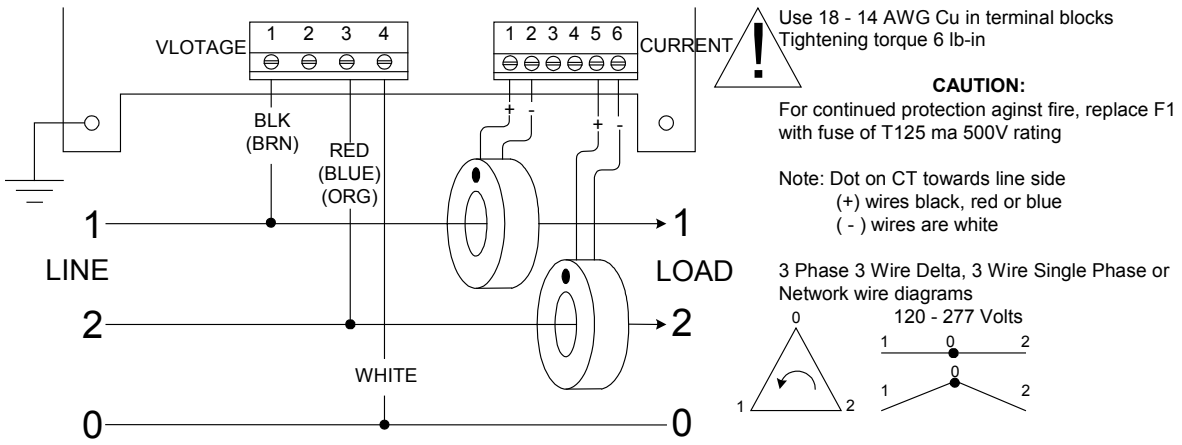

Figure 4 Wiring Diagram for a **3-Phase 3-Wire Delta, Single Phase 3 Wire & Network Service**

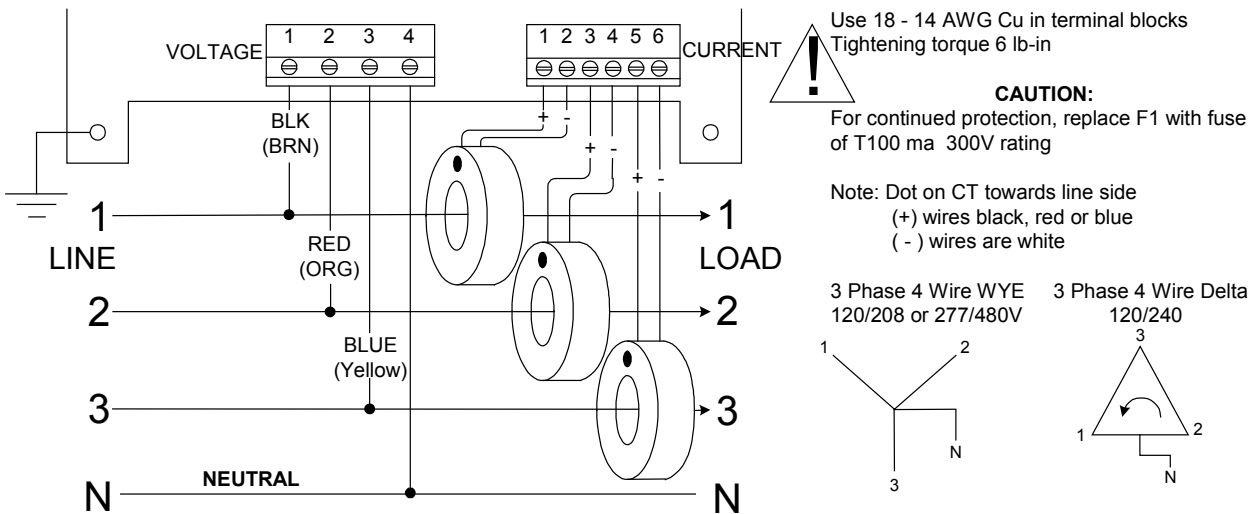
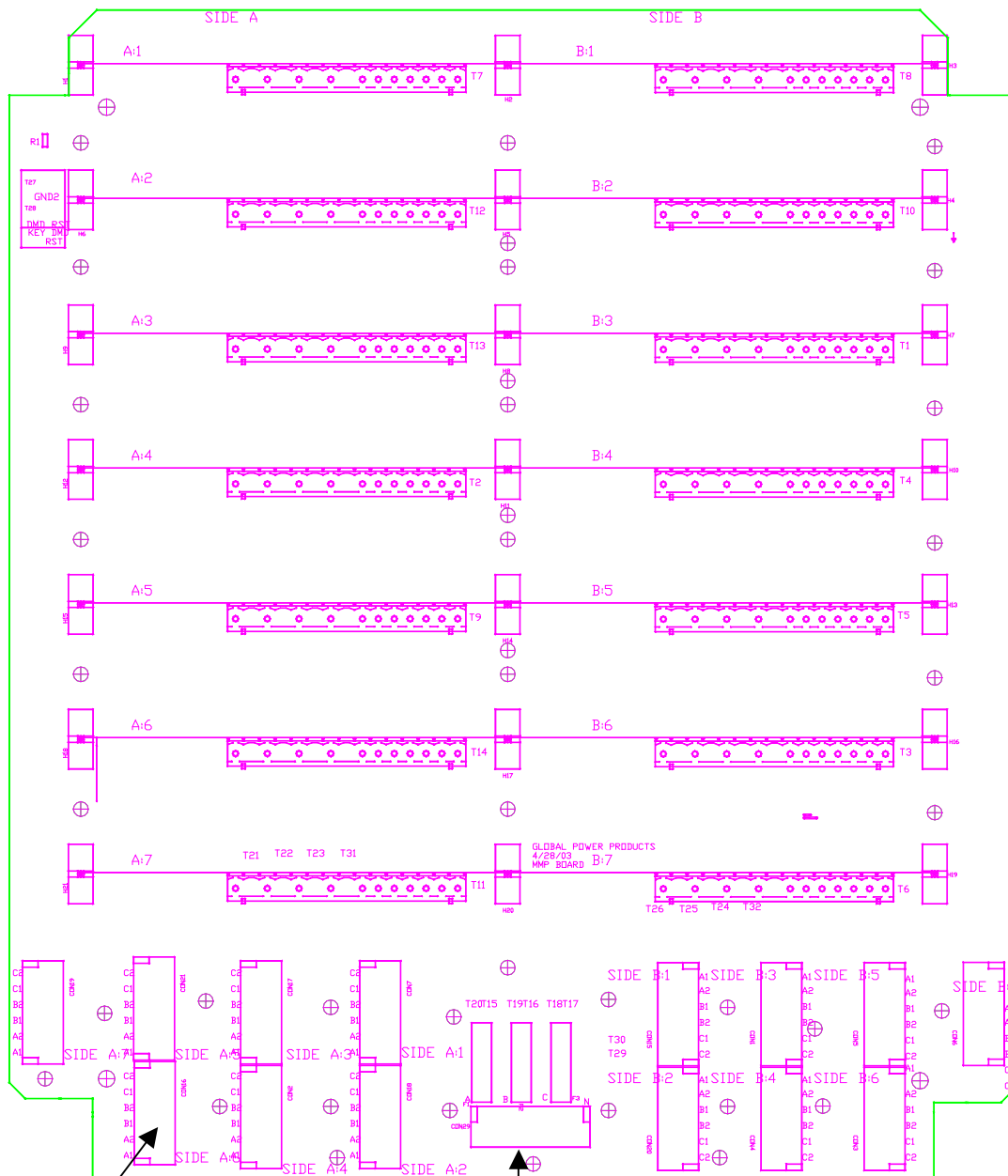

Figure 5 Wiring Diagram for a **3-Phase 4-Wire WYE, 3-Phase 4-Wire Delta**

This is Side A

This is Side B



Current Transformer inputs, 1 block per meter

Voltage Connection Block, Connections are A, B, C and Neutral

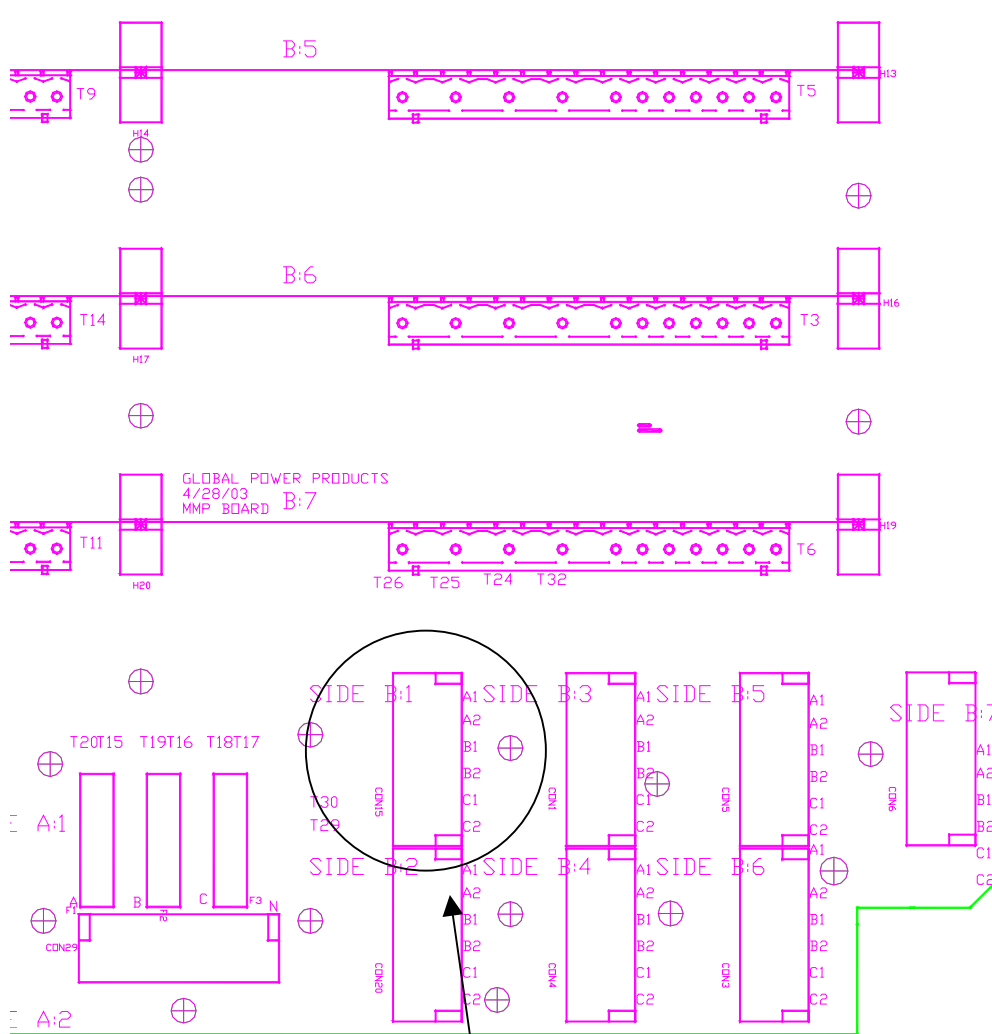

Current Transformer Inputs for the Right Side

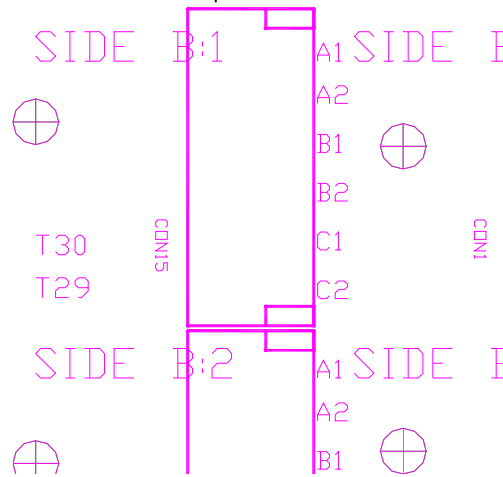

CAUTION

Do not mix the phases of the voltage and current leads. For example, Phase A voltage tap should match phase A Current Transformer leads. Incorrect metering will result, as well as an error being displayed if the leads are improperly connected.

Step 6 Close cover and Seal:

- a) Latch the two captive snap flanges on the right side of the enclosure cover.
- b) Install the wire seal or pad lock in the cover latch.
- c) Remove any protective covering on the face of the meter.

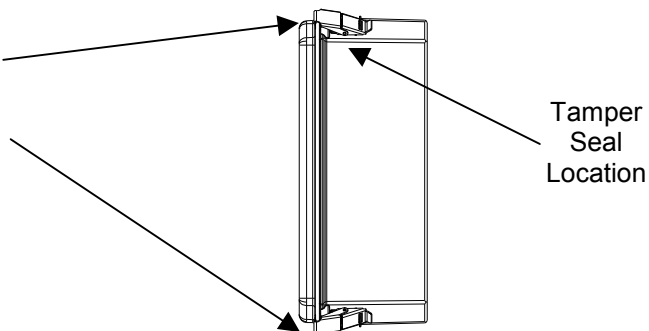

MODES OF OPERATION

NORMAL MODE

The meters in a MMP operate in two modes a "NORMAL" mode and a "TEST" mode. The meter powers-up and runs in the NORMAL mode. This is indicated by the "NRML" annunciator in the lower left corner as in the figure below;



ACC indicates the meter is "*accumulating*" properly. And the annunciator in the upper right hand corner indicates the metering parameter being displayed. In this case Total **KWH** is displayed.

TEST MODE

The individual Ener-Comm meter in a MMP can be put in a diagnostic "TEST" mode by placing a magnet to the right of the display. The meter will sequentially display the voltage, the current and the instantaneous Demand for each phase. If a communication module is attached the meter will display the programmed ID number.

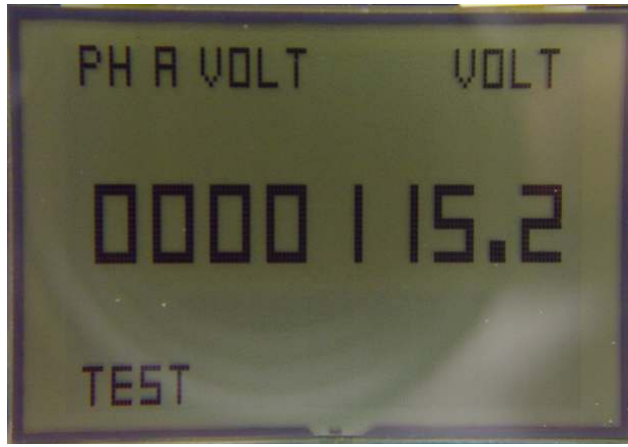

Error Mode

If the individual Ener-Comm meter detects an error in the wiring "ERROR" will be displayed in the lower left corner of the LCD.

Error Displayed	7000	Reverse CTs or Cross Phased
	12000	Brown-Out or Low Voltage

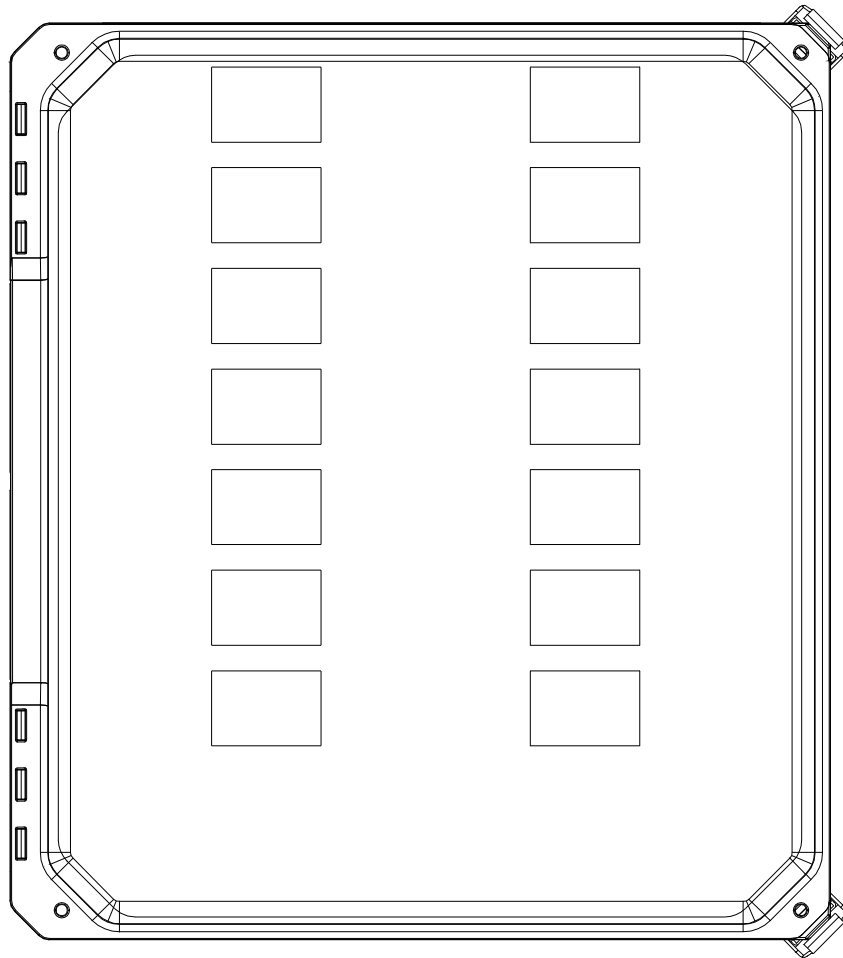

WARRANTY

All products manufactured by North American Power Products and Global Power Products are guaranteed against defects in material and workmanship for a period of one year from the date of shipment. In the unlikely event a meter needs calibrated or a customer wants to verify the calibration, a service technician can verify the calibration in the field or the meter can be returned to the factory for recalibration. In either case a calibration fee may be charged.

All guarantees are limited to repair or replacement of the defective product.

All products returned to the factory for repair **must be accompanied by a Return Authorization number** and it will be inspected to determine the cause of the failure. Metering equipment determined to have been subjected to an improper installation, neglect or misuse will be repaired or replaced at a standard rate, pending customer approval.

FCC PART 15, CLASS A

The ENER-COMM meter has been tested and found to comply with the limits for a Class A digital device, pursuant to Part 15 of the FCC rules. These limits are designed to provide reasonable protection from harmful interference when the equipment is operated in a commercial environment.

This equipment generates, uses, and can radiate radio frequency energy and, if not installed and used in accordance with the instruction manual, may cause harmful interference to radio communications.

Operation of this equipment in a residential area may cause harmful interference, in which case you will be required to correct the interference at your own expense.

Any modifications or changes to the equipment, not expressly approved by the party responsible for compliance, could void your authority to operate the equipment.

FCC PART 15, CLASS B

The ENER-COMM meter has been tested and found to comply with the limits for a Class B digital device, pursuant to Part 15 of the FCC rules. These limits are designed to provide reasonable protection against harmful interference when the equipment is operated in a residential environment.

This equipment generates, uses, and can radiate radio frequency energy and, if not installed and used in accordance with the instruction manual, may cause harmful interference to radio communications. However, there is no guarantee that interference will not occur in a particular installation. If this equipment does cause harmful interference to radio or television reception, which can be determined by turning the equipment off and on, you are encouraged to try to correct the interference by one or more of the following measures:

- Reorient or relocate the receiving antenna.
- Increase the separation between the equipment and receiver.
- Connect the equipment into an outlet on a circuit different from that to which the receiver is connected.
- Consult the dealer or an experienced radio/TV technician for help.

Any modifications or changes to the equipment, not expressly approved by the party responsible for compliance, could void your authority to operate the equipment.